

VINKOR ADJUSTABLE POT CORE

LA2103

35mm adjustable pot core specially designed for high quality inductors operating at frequencies up to approximately 20kc/s.

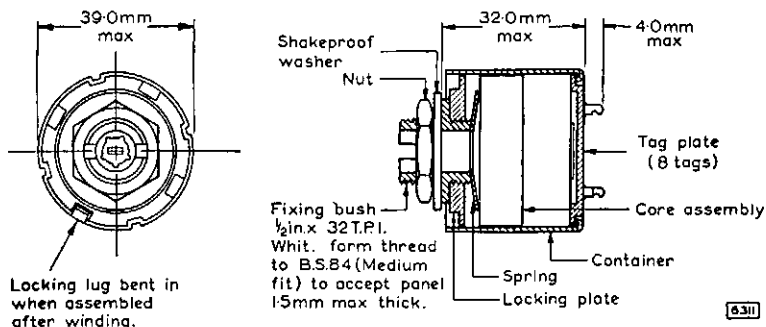

6311

ELECTRICAL AND MAGNETIC PROPERTIES OF CORE ASSEMBLY

with adjuster at nominal mid-range position.

Effective permeability	μ_e	*160
Turns for 1mH	α	34.3
Initial permeability of material	μ_i	> 1150
Residual plus eddy current dissipation factor	$\tan \delta_{r+e}$	
Typical value measured at:		
B max. < 0.5 gauss, f = 30kc/s		1.3×10^{-3}
B max. < 0.5 gauss, f = 100kc/s		3.6×10^{-3}
Hysteresis factor	$F_h = \frac{R}{L} \cdot \frac{1}{f \sqrt{L}}$	< 12.7
Temperature coefficient	$\frac{\Delta L}{L \cdot \Delta T}$	-160 to + 320 p.p.m./°C.

*Without the adjuster, the effective permeability of the core is $150.4 \pm 3\%$.

GENERAL NOTES

Coil formers are not supplied with the Vinkor but should be ordered separately. For details see page 3.

For correct assembly and alignment of piece parts use aligning plug DT2036. See separate data sheet.

Non-magnetic screwdriver type DT2047 should be used for precise adjustment of inductance.



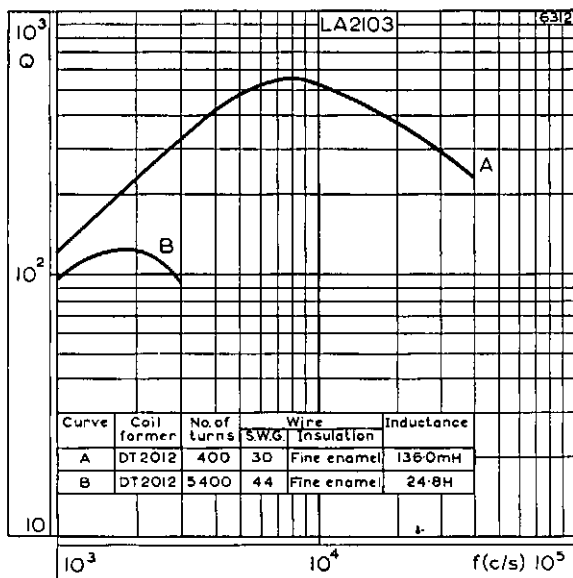

TYPICAL Q CURVES

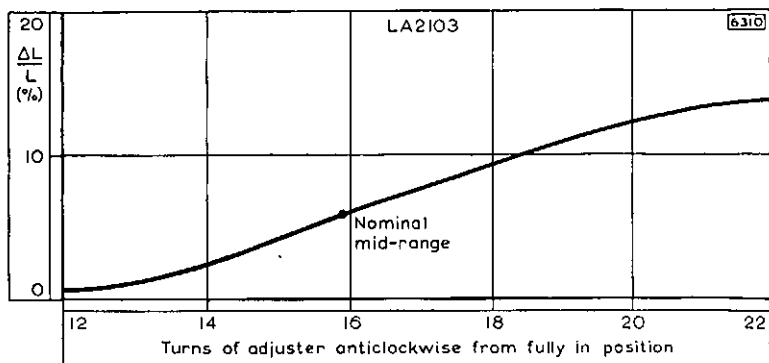

ADJUSTMENT CURVE

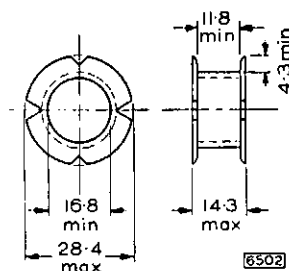

All dimensions in mm

Single section coil former

DT2012— nylon, maximum working temperature=130°C.

DT2085—polystyrene, maximum working temperature=80°C.

The nylon is a low water absorbent grade. Nominal winding area=55.6mm².

**WINDING DATA FOR FULLY WOUND FORMER
ENAMELLED COPPER WIRE TO B.S.1844 (FINE COVERING)**

S.W.G.	Cu. dia. (in.)	Turns	Resistance (Ω)
20	0.036	48	0.088
21	0.032	67	0.160
22	0.028	77	0.23
23	0.024	108	0.45
24	0.022	136	0.68
25	0.020	168	1.05
26	0.018	188	1.4
27	0.0164	234	2.1
28	0.0148	290	3.2
29	0.0136	340	4.5
30	0.0124	400	6.4
31	0.0116	460	8.4
32	0.0108	525	11
33	0.0100	605	15
34	0.0092	720	21
35	0.0084	850	30
36	0.0076	1030	44
37	0.0068	1260	67
38	0.0060	1660	115
39	0.0052	2100	195
40	0.0048	2500	270
41	0.0044	2900	370
42	0.0040	3500	540
43	0.0036	4450	840
44	0.0032	5400	1300
45	0.0028	7100	2200
46	0.0024	9400	4000
47	0.0020	13700	8500

WINDING DATA FOR FULLY WOUND FORMER

SILK COVERED BUNCHED ENAMELLED COPPER CONDUCTORS TO B.S.1258

Strands	S.W.G.	Strand dia. (in.)	Insulation	Turns	Resistance (Ω)
81	43	0.0036	D.S.C.	27	0.063
350	48	0.0016	D.S.C.	28	0.076
315	48	0.0016	D.S.C.	40	0.120
81	44	0.0032	D.S.C.	42	0.125
280	48	0.0016	D.S.C.	42	0.145
252	48	0.0016	D.S.C.	44	0.165
81	45	0.0028	D.S.C.	46	0.175
224	48	0.0016	D.S.C.	46	0.195
200	48	0.0016	D.S.C.	60	0.29
180	48	0.0016	D.S.C.	62	0.33
48	44	0.0032	D.S.C.	65	0.32
160	48	0.0016	D.S.C.	67	0.40
140	48	0.0016	D.S.C.	87	0.59
30	43	0.0036	S.S.C.	93	0.59
81	47	0.0020	D.S.C.	96	0.72
30	44	0.0032	S.S.C.	122	0.98
100	48	0.0016	D.S.C.	126	1.2
30	45	0.0028	S.S.C.	160	1.7
81	48	0.0016	D.S.C.	160	1.9
30	46	0.0024	S.S.C.	180	2.5
19	45	0.0028	S.S.C.	240	4.0
30	47	0.0020	S.S.C.	270	5.5
7	42	0.0040	S.S.C.	325	7.1
10	45	0.0028	S.S.C.	370	12
9	45	0.0028	S.S.C.	440	15
7	45	0.0028	S.S.C.	600	27
3	44	0.0032	S.S.C.	855	68
3	46	0.0024	S.S.C.	1290	180

VINKOR ADJUSTABLE POT CORE

LA2104

35mm adjustable pot core specially designed for high quality inductors operating at frequencies up to approximately 50kc/s.

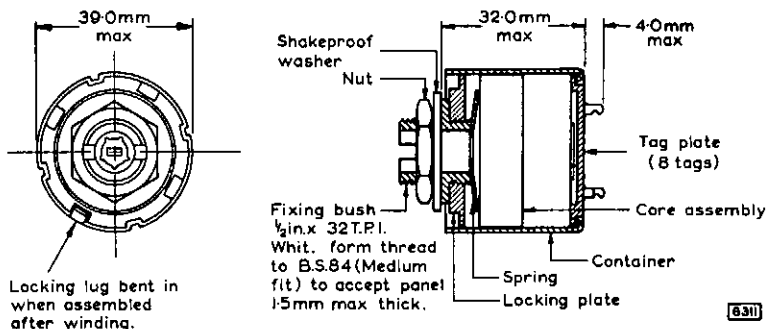

ELECTRICAL AND MAGNETIC PROPERTIES OF CORE ASSEMBLY

with adjuster at nominal mid-range position.

Effective permeability	μ_e	*100
Turns for 1mH	α	43.4
Initial permeability of material	μ_i	> 1150
Residual plus eddy current dissipation factor	$\tan \delta_{r+e}$	
Typical value measured at:		
B max. < 0.5 gauss, f = 30kc/s		0.8×10^{-3}
B max. < 0.5 gauss, f = 100kc/s		2.3×10^{-3}
Hysteresis factor	$F_h = \frac{R}{L} \cdot \frac{1}{I \cdot f \sqrt{L}}$	< 6.3
Temperature coefficient	$\frac{\Delta L}{L \cdot \Delta T}$	-100 to +200 p.p.m./°C

*Without the adjuster, the effective permeability of the core is $89.7 \pm 3\%$.

GENERAL NOTES

Coil formers are not supplied with the Vinkor but should be ordered separately. For details see page 3.

For correct assembly and adjustment of piece parts use aligning plug type DT2036. See separate data sheet.

Non-magnetic screwdriver type DT2047 should be used for precise adjustment of inductance.

LA2104

VINKOR ADJUSTABLE POT CORE

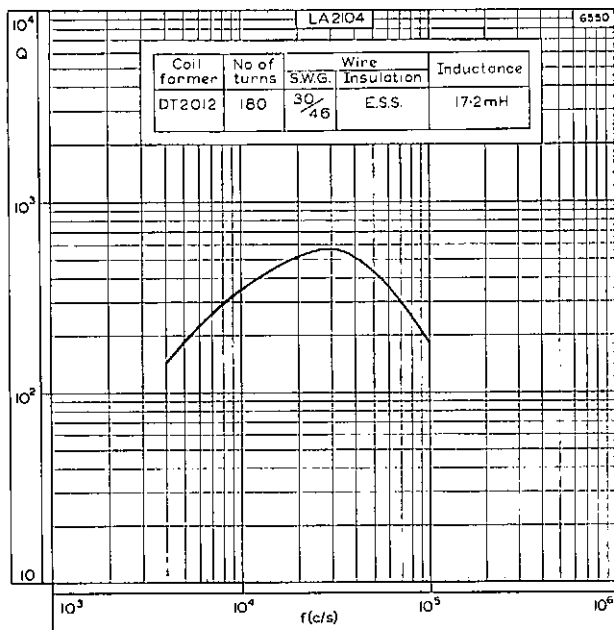

TYPICAL Q CURVE

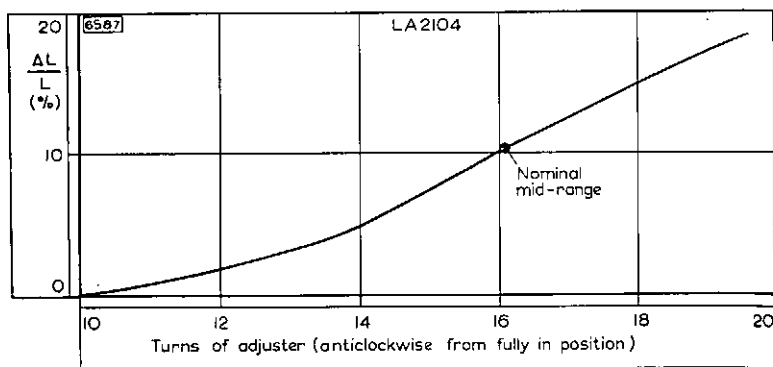

ADJUSTMENT CURVE

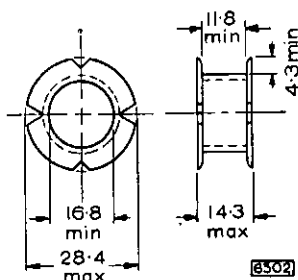

All dimensions in mm

Single section coil former

DT2012 - nylon, maximum working temperature = 130°C.

DT2085 - polystyrene, maximum working temperature = 80°C.

The nylon is a low water absorbent grade. Nominal winding area = 55.6mm².

**WINDING DATA FOR FULLY WOUND FORMER
ENAMELLED COPPER WIRE TO B.S.1844 (FINE COVERING)**

S.W.G.	Cu. dia. (in.)	Turns	Resistance (Ω)
20	0.036	48	0.088
21	0.032	67	0.160
22	0.028	77	0.23
23	0.024	108	0.45
24	0.022	136	0.68
25	0.020	168	1.05
26	0.018	188	1.4
27	0.0164	234	2.1
28	0.0148	290	3.2
29	0.0136	340	4.5
30	0.0124	400	6.4
31	0.0116	460	8.4
32	0.0109	525	11
33	0.0100	605	15
34	0.0092	720	21
35	0.0084	850	30
36	0.0076	1030	44
37	0.0068	1260	67
38	0.0060	1660	115
39	0.0052	2100	195
40	0.0048	2500	270
41	0.0044	2900	370
42	0.0040	3500	540
43	0.0036	4450	840
44	0.0032	5400	1300
45	0.0028	7100	2200
46	0.0024	9400	4000
47	0.0020	13700	8500

WINDING DATA FOR FULLY WOUND FORMER

SILK COVERED BUNCHED ENAMELLED COPPER CONDUCTORS TO B.S.1258

Strands	S.W.G.	Strand dia. (in.)	Insulation	Turns	Resistance (Ω)
81	43	0.0036	D.S.C.	27	0.063
350	48	0.0016	D.S.C.	28	0.076
315	48	0.0016	D.S.C.	40	0.120
81	44	0.0032	D.S.C.	42	0.125
280	48	0.0016	D.S.C.	42	0.145
252	48	0.0016	D.S.C.	44	0.165
81	45	0.0028	D.S.C.	46	0.175
224	48	0.0016	D.S.C.	46	0.195
200	48	0.0016	D.S.C.	60	0.29
180	48	0.0016	D.S.C.	62	0.33
48	44	0.0032	D.S.C.	65	0.32
160	48	0.0016	D.S.C.	67	0.40
140	48	0.0016	D.S.C.	87	0.59
30	43	0.0036	S.S.C.	93	0.59
81	47	0.0020	D.S.C.	96	0.72
30	44	0.0032	S.S.C.	122	0.98
100	48	0.0016	D.S.C.	126	1.2
30	45	0.0028	S.S.C.	160	1.7
81	48	0.0016	D.S.C.	160	1.9
30	46	0.0024	S.S.C.	180	2.5
19	45	0.0028	S.S.C.	240	4.0
30	47	0.0020	S.S.C.	270	5.5
7	42	0.0040	S.S.C.	325	7.1
10	45	0.0028	S.S.C.	370	12
9	45	0.0028	S.S.C.	440	15
7	45	0.0028	S.S.C.	600	27
3	44	0.0032	S.S.C.	855	68
3	46	0.0024	S.S.C.	1290	180

VINKOR ADJUSTABLE POT CORE

LA2105

35mm adjustable pot core specially designed for high quality inductors operating at frequencies up to approximately 200kc/s.

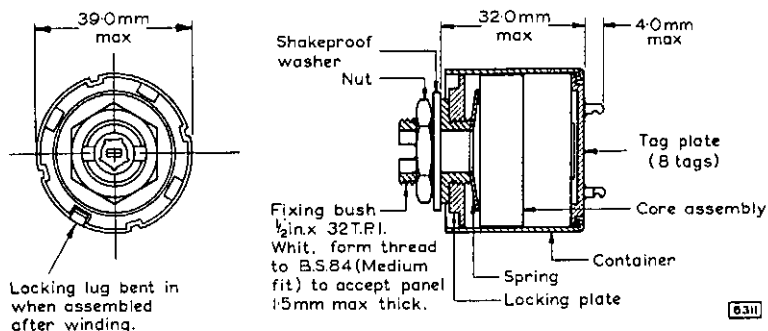

ELECTRICAL AND MAGNETIC PROPERTIES OF CORE ASSEMBLY

with adjuster at nominal mid-range position.

Effective permeability	μ_e	*63
Turns for 1mH	α	54.7
Initial permeability of material	μ_i	> 1150

Residual plus eddy current
dissipation factor

$\tan \delta_{r+e}$

Typical value measured at:

B max. < 0.5 gauss, $f = 30$ kc/s

0.5×10^{-3}

B max. < 0.5 gauss, $f = 100$ kc/s

1.4×10^{-3}

Hysteresis factor

$$F_h = \frac{R}{L} \cdot \frac{1}{f \sqrt{L}} < 3.15$$

Temperature coefficient

$$\frac{\Delta L}{L \cdot \Delta T} \quad -63 \text{ to } +126 \text{ p.p.m./}^\circ\text{C}$$

*Without the adjuster, the effective permeability of the core is $60.1 \pm 2\%$.

GENERAL NOTES

Coil formers are not supplied with the Vinkor but should be ordered separately. For details see page 3.

For correct assembly and adjustment of piece parts use aligning plug type DT2036. See separate data sheet.

Non-magnetic screwdriver type DT2047 should be used for precise adjustment of inductance.

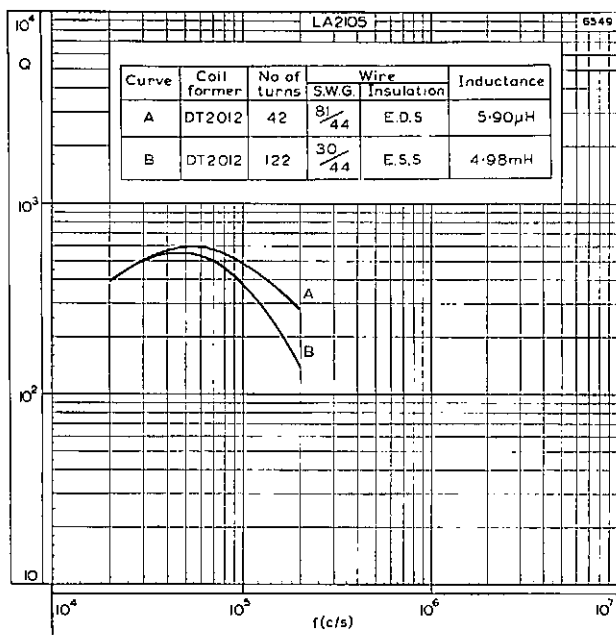

TYPICAL Q CURVES

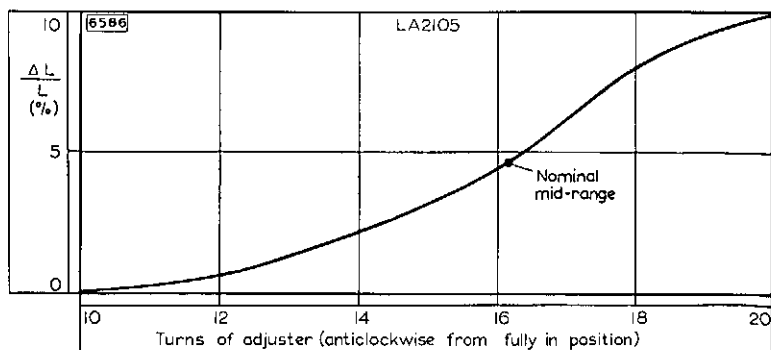

ADJUSTMENT CURVE

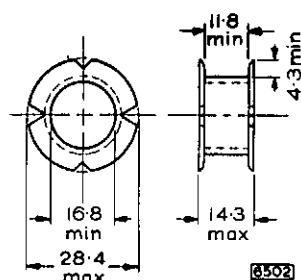

All dimensions in mm

Single section coil former

DT2012 - nylon, maximum working temperature = 130°C.

DT2085 - polystyrene, maximum working temperature = 80°C.

The nylon is a low water absorbent grade. Nominal winding area = 55.6mm².

WINDING DATA FOR FULLY WOUND FORMER
ENAMELLED COPPER WIRE TO B.S.1844 (FINE COVERING)

S.W.G.	Cu. dia. (in.)	Turns	Resistance (Ω)
20	0.036	48	0.088
21	0.032	67	0.160
22	0.028	77	0.23
23	0.024	108	0.45
24	0.022	136	0.68
25	0.020	168	1.05
26	0.018	188	1.4
27	0.0164	234	2.1
28	0.0148	290	3.2
29	0.0136	340	4.5
30	0.0124	400	6.4
31	0.0116	460	8.4
32	0.0108	525	11
33	0.0100	605	15
34	0.0092	720	21
35	0.0084	850	30
36	0.0076	1030	44
37	0.0068	1260	67
38	0.0060	1660	115
39	0.0052	2100	195
40	0.0048	2500	270
41	0.0044	2900	370
42	0.0040	3500	540
43	0.0036	4450	840
44	0.0032	5400	1300
45	0.0028	7100	2200
46	0.0024	9400	4000
47	0.0020	13700	8500

WINDING DATA FOR FULLY WOUND FORMER

SILK COVERED BUNCHED ENAMELLED COPPER CONDUCTORS
TO B.S.1258

Strands	S.W.G.	Strand dia. (in.)	Insulation	Turns	Resistance (Ω)
81	43	0.0036	D.S.C.	27	0.063
350	48	0.0016	D.S.C.	28	0.076
315	48	0.0016	D.S.C.	40	0.120
81	44	0.0032	D.S.C.	42	0.125
280	48	0.0016	D.S.C.	42	0.145
252	48	0.0016	D.S.C.	44	0.165
81	45	0.0028	D.S.C.	46	0.175
224	48	0.0016	D.S.C.	46	0.195
200	48	0.0016	D.S.C.	60	0.29
180	48	0.0016	D.S.C.	62	0.33
48	44	0.0032	D.S.C.	65	0.32
160	48	0.0016	D.S.C.	67	0.40
140	48	0.0016	D.S.C.	87	0.59
30	43	0.0036	S.S.C.	93	0.59
81	47	0.0020	D.S.C.	96	0.72
30	44	0.0032	S.S.C.	122	0.98
100	48	0.0016	D.S.C.	126	1.2
30	45	0.0028	S.S.C.	160	1.7
81	48	0.0016	D.S.C.	160	1.9
30	46	0.0024	S.S.C.	180	2.5
19	45	0.0028	S.S.C.	240	4.0
30	47	0.0020	S.S.C.	270	5.5
7	42	0.0040	S.S.C.	325	7.1
10	45	0.0028	S.S.C.	370	12
9	45	0.0028	S.S.C.	440	15
7	45	0.0028	S.S.C.	600	27
3	44	0.0032	S.S.C.	855	68
3	46	0.0024	S.S.C.	1290	180