



Data Library

Universal counter ic 7216A

Stock number 307-941

The RS7216A Universal Counter IC is a fully integrated 8 digit universal counter, which combines a high frequency oscillator, a decade timebase counter, an eight decade data counter and latches, a seven segment decoder, digit multiplexers and eight segment and eight digit drivers which can directly drive large LED displays (e.g. 0.5" multiplexed displays 587-024). The counter inputs have a maximum frequency of 10MHz in frequency and unit counter modes and 2MHz in the other modes. However, the maximum frequency may be extended by use of prescaling techniques e.g. to increase the range to 50MHz a 74LS90 decade counter (307-610) may be used or to increase the range to at least 100MHz the RS÷100 Prescaler IC (307-474) may be employed. Both the inputs are digital inputs, and therefore in many applications the input signals will need amplification and level shifting to give the correct digital signals.

The RS7216A can function as a frequency counter, period counter, frequency ratio (F_A/F_B) counter, time interval counter or as a totalising counter. The counter normally uses a 10MHz quartz crystal timebase (but a 1MHz quartz crystal timebase is possible), in addition the timebase may be driven from an external oscillator. For period and time interval measurement, the 10MHz timebase gives a 0.1µ sec resolution. In period average and time interval average the resolution can be in the nano-second range. In the frequency mode, the user can select accumulation times of 0.01 sec, 0.1 sec, 1 sec and 10 sec. With a 10 sec accumulation time, the frequency can be displayed to an accuracy of 0.1Hz in the least significant digit. There is 0.2 sec between measurements in all ranges.

The RS7216A incorporates leading zero blanking and automatic decimal point setting as the range is changed. The reading displayed is in kilohertz in the frequency modes and micro-seconds for the time measurement modes. The display is multiplexed at 500Hz with a 12.5% duty cycle for each digit with a typical peak segment current of 25mA. In the display off mode, both digit drivers and segment drivers are turned off allowing the display to be used for other functions if required.

A ready made p.c.b. (434-548) is available facilitating construction of a complete universal

counter, including provision for ÷100 prescalers, time interval circuitry and p.c.b. rotary switches.

In addition a display p.c.b. (434-532) is available designed to accept eight 0.5" seven segment LED displays and one 0.2" discrete LED for overflow indication.

Features

- Functions as a frequency counter, period counter, unit counter, frequency ratio counter or time interval counter
- Four internal gate times: 0.01 sec, 0.1 sec, 1 sec, 10 sec in frequency counter mode
- 1 cycle, 10 cycles, 100 cycles, 1000 cycles in period, frequency ratio and time interval modes
- Measures period from 0.5µ sec to 10 sec
- Output drivers will directly drive both digits and segments of large LED displays
- Single nominal 5V supply required
- Stable high frequency oscillator, uses either 1MHz or 10MHz crystal
- Internally generated multiplex timing with interdigit blanking, leading zero blanking and overflow indication
- Decimal point and leading zero blanking controlled directly by the chip
- Display off mode turns off display and puts chip into low power mode
- Hold and reset inputs for additional flexibility
- All terminals protected against static discharge.

Figure 1: Pin connections

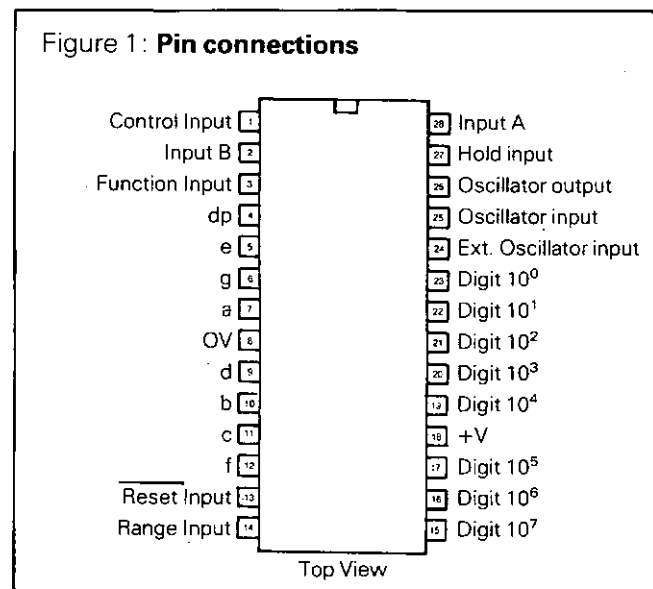
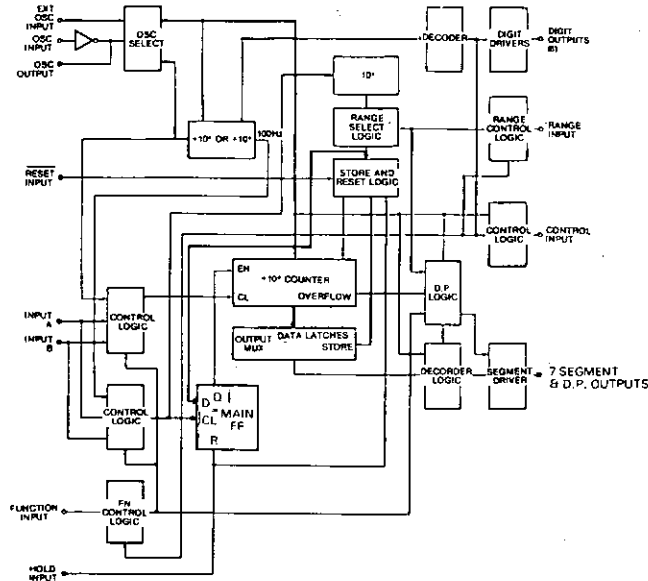

Figure 2: Block diagram



Absolute maximum ratings

- Maximum supply voltage (+V) _____ 6.5V
- Maximum digit output current _____ 400mA
- Maximum segment output current _____ 60mA
- Voltage on any input or output terminal [1] _____ +V+0.3V to -0.3V
- Maximum operating temperature range _____ -20°C to +70°C
- Maximum storage temperature range _____ -55°C to +125°C

Notes:

1. The RS7216 may be triggered into a destructive latchup mode if either input signals are applied before the power supply is applied or if input or outputs are forced to voltages exceeding +V by more than 0.3V.

Figure 4: **Waveform for guaranteed minimum F_{B MAX} and F_{A MAX} for function = period and time interval.**

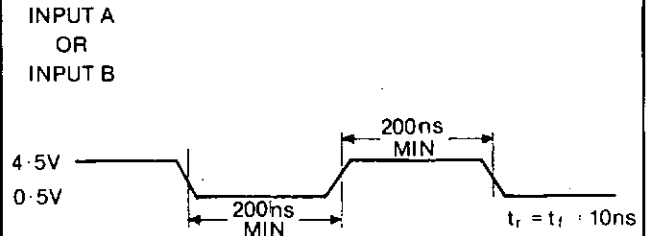

Figure 3: **Waveform for guaranteed minimum F_{A MAX} function = frequency, frequency ratio, unit counter.**

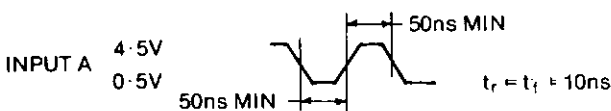
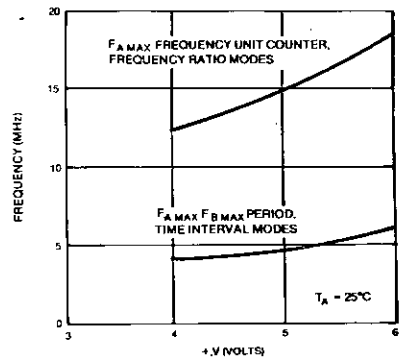

Figure 5: **Typical operating characteristics**



F_{A MAX}, F_{B MAX} as a Function of +V

Electrical characteristics

Test conditions: +V=5.0V, Test Circuit, TA=25°C, unless otherwise specified.

Parameter	Symbol	Condition	Min.	Typ.	Max.	Units
Operating Supply Current	I_{DD}	Display Off, Unused Inputs to 0V		2	5	mA
Supply Voltage Range		-20°C < T _A < +70°C, Input A, Input B Frequency at F _{MAX}	4.75		6.0	V
Maximum Frequency Input A, Pin 28	F _A MAX	-20°C < T _A < +70°C 4.75 < +V ≤ 6.0V, Figure 5 Function = Frequency, Ratio, Unit Counter Function = Period, Time Interval	10 2.5			MHz MHz
Maximum Frequency Input B, Pin 2	F _B MAX	-20°C < T _A < +70°C 4.75V < +V ≤ 6.0V Figure 3	2.5			MHz
Minimum Separation Input A to Input B Time Interval Function		-20°C < T _A < +70°C 4.75V < +V ≤ 6.0V Figure 4	250			ns
Maximum Osc. Freq. and Ext. Osc. Frequency		-20°C < T _A < +70°C 4.75 < +V ≤ 6.0V	10			MHz
Minimum Ext. Osc. Freq.					100	KHz
Multiplex Frequency	f _{max}	f _{OSC} = 10MHz		500		Hz
Time Between Measurements		f _{OSC} = 10MHz		200		ms
Input Voltages: Pins 2, 13, 25, 27, 28 Input Low Voltage	V _{IL}	-20°C < T _A < +70°C			1.0	V
Input High Voltage	V _{IH}		3.5			V
Input Resistance to +V Pins 13, 24	R	V _{IN} = +V - 1.0V	100	400		kΩ
Input Leakage Pin 2, 27, 28	I _L				20	μA
Digit Driver: Pins 15, 16, 17, 19, 20, 21, 22, 23 High Output Current Low Output Current	I _{OH} I _{OL}	V _{OUT} = +V - 2.0V V _{OUT} = +1.0V	-140	-180 +0.3		mA mA
Segment Driver: Pins 4, 5, 6, 7, 9, 10, 11, 12 Low Output Current High Output Current	I _{OL} I _{OH}	V _{OUT} = +1.5V V _{OUT} = +V - 2.5V	25	35 -100		mA μA
Multiplex Inputs: Pins 1, 3, 14 Input Low Voltage Input High Voltage Input Resistance to +V	V _{IL} V _{IH} R	V _{IN} = +1.0V	+2.0 50		100	V V kΩ

Applications notes**General
Inputs A and B**

Inputs A and B are digital inputs with a typical switching threshold of 2.0V at +V=5.0V. For optimum performance the peak-to-peak input signal should be at least 50% of the supply voltage and centred about the switching voltage. When these inputs are being driven from TTL logic, it is desirable to use a pullup resistor. The circuit counts high to low transition at both inputs.

Note: The amplitude of the input should not exceed the supply, otherwise, the circuit may be damaged.

Multiplexed inputs

The function, range and control inputs are time multiplexed to select the input function desired. This is achieved by connecting the appropriate digit driver output to the inputs. The function, range and control inputs must be stable during the last half of each digit output (typically 125μsec). The multiplex inputs are active high for a common anode display. Noise on the multiplex inputs can cause improper operation. This is particularly true when the unit counter mode of operation is selected, since changes in voltage on the digit drivers can be capacitively coupled through the LED diodes to the multiplex inputs. For maximum noise immunity, a

10k Ω resistor should be placed in series with the multiplex inputs and a 68pF capacitor to decouple the inputs to 0V as shown in figure 13.

Table 1 shows the functions selected by each digit for these inputs.

Control input functions

Display Test — All segments are enabled continuously, giving display of all 8's with decimal points. The display will be blanked if Display Off is selected at the same time.

Display Off — to enable the Display Off mode it is necessary to connect D10³ to the control input and have the HOLD input at +V. The chip will remain in the Display Off mode until HOLD is switched back to 0V. While in the Display Off mode, the segment and digit driver outputs are open. During Display Off the oscillator continues to run with a typical supply current of 1.5mA with a 10MHz crystal and no measurements are made. In addition, inputs to the multiplexed inputs will have no effect. A new measurement is initiated when the HOLD input is switched to 0V.

1 MHz Enable — The 1 MHz enable mode allows use of 1 MHz crystal with the same digit multiplex rate and time between measurements as with a 10 MHz crystal. The decimal point is also shifted one digit to the right in Period and Time Interval, since the least significant digit will be in μ sec increments rather than 0.1 μ sec increments.

External Oscillator Enable — In this mode the external oscillator input is used instead of the on-chip oscillator for Timebase input and Main Counter input in Period and Time interval modes. The on-chip oscillator will continue to function when the external oscillator is selected. The external oscillator input frequency must be greater than 100 kHz or the chip will reset itself to enable the on-chip oscillator (The RS 10MHz crystal oscillator is ideally suited as an external oscillator).

Range Input — The range input selects whether the measurement is made for 1, 10, 100, 1000 counts of the reference counter. In all functional modes except Unit Counter a change in the range input will stop the measurement in progress without updating the display and then initiate a new measurement. This prevents an erroneous first reading after the Range Input is changed. (N.B. Readings displayed in kilohertz or microseconds)

Function Input — The six functions that can be selected are:

Frequency, Period, Time Interval, Unit Counter, Frequency Ratio and Oscillator Frequency.

These functions select which signal is counted into the Main Counter and which signal is counted by the reference counter as shown in Table 2. In Time Interval a flip flop is toggled first by a 1-0 transition of Input A then by a 1-0 transition of Input B. The oscillator is gated into the Main Counter from the time Input A toggles the flip flop until Input B gates the flip flop. (For complete description of workings

of Time Interval see later section figure 18). A change in the function input will stop the measurement in progress without updating the display and then initiate a new measurement. This prevents an erroneous first reading after the Function Input is changed.

Table 1

	Function	Digit
Function Input Pin 3	Frequency	D10 ⁰
	Period	D10 ⁷
	Frequency Ratio	D10 ¹
	Time Interval	D10 ⁴
	Unit Counter	D10 ³
	Oscillator Frequency	D10 ²
Range Input Pin 14	0.01 sec/1 hertz	D10 ⁰
	0.1 sec/10 hertz	D10 ¹
	1 sec/100 hertz	D10 ²
	10 sec/1k hertz	D10 ³
Control Input Pin 1	Blank Display	D10 ³ and Hold
	Display Test	D10 ⁷
	1 MHz Enable	D10 ¹
	External Oscillator Enable	D10 ⁰

Table 2

Description	Main Counter	Reference Counter
Frequency (FA)	Input A	100 Hz (Oscillator $\div 10^5$ or 10^4)
Period (TA)	Oscillator	Input A
Ratio (FA/FB)	Input A	Input B
Time Interval (A - B)	Osc (Time Interval FF)	Time Interval FF
Unit Counter (Count A)	Input A	Not Applicable
Osc. Freq. (f _{osc})	Oscillator	100 Hz (Oscillator $\div 10^5$ or 10^4)

Hold Input — When the Hold Input is at +V, any measurement in progress is stopped, the main counter is reset and the chip is held ready to initiate a new measurement. The latches which hold the main counter data are not updated so the last complete measurement is displayed. When Hold is changed to 0V, a new measurement is initiated.

Reset Input — The Reset Input is the same as a Hold Input, except the latches for the Main Counter are enabled, resulting in an output of all zeros.

Display considerations

The display is multiplexed at a 500 Hz rate with a digit time of 244 μ sec. An interdigit blanking time of 6 μ sec is used to prevent ghosting between digits. The decimal point and leading zero blanking have been implemented for right hand decimal point displays. Any zeros following the decimal point will not be blanked. Also, the leading zero blanking will be disabled when the Main Counter overflows.

The RS7216 is designed to drive common anode LED displays at peak current of 25mA/segment, using displays with $V_F=1.8V$ at 25mA. The average DC current will be over 3mA under these conditions. Resistors can be added in series with the segment drivers to limit the display current in very efficient displays, if required. Figures 6, 7 and 8 show the digit and segment currents as a function of output voltage. (V_{OUT} referred to 0V).

To obtain additional brightness from the displays, +V may be increased up to 6.0V. However, care should be taken to see that maximum power and current ratings are not exceeded.

Figure 8: **Typical I_{SEG} VS. V_{OUT} (temperature varied)**

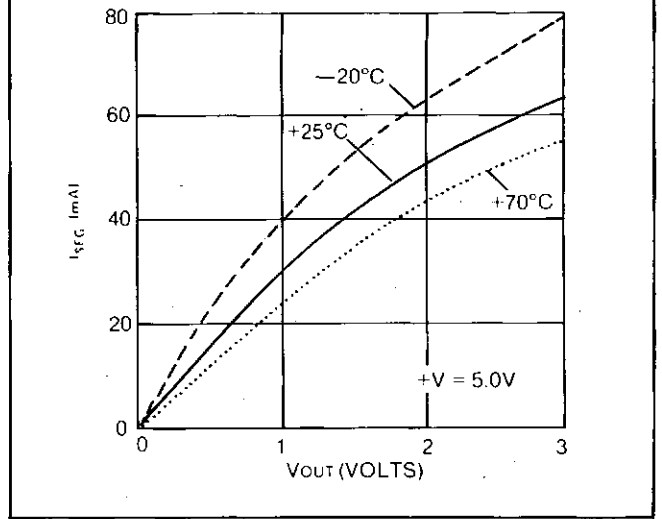

The segment and digit outputs in the RS7216 are not directly compatible with either TTL or CMOS logic. Therefore, level shifting with discrete transistors may be required to use these outputs as logic signals.

Figure 6: **Typical I_{DIG} VS.**

+V — V_{OUT} ($4.5V < +V < 6.0V$)

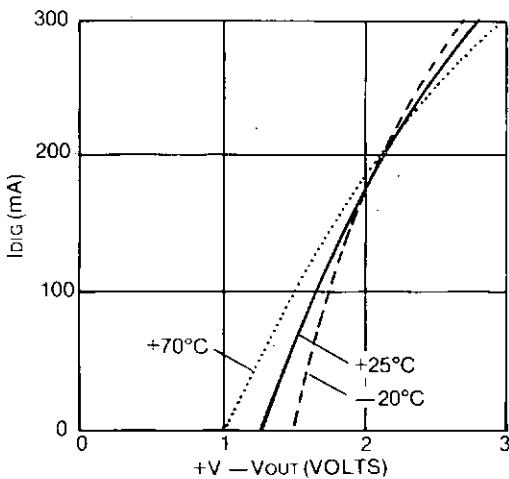

Segment Identification:

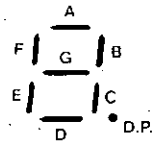

N.B. The correct display to use with this device is a common anode with right hand decimal point e.g. RS multiplexed seven segment display Stock No 587-024.

Figure 7: **Typical I_{SEG} VS V_{OUT} (+V varied)**

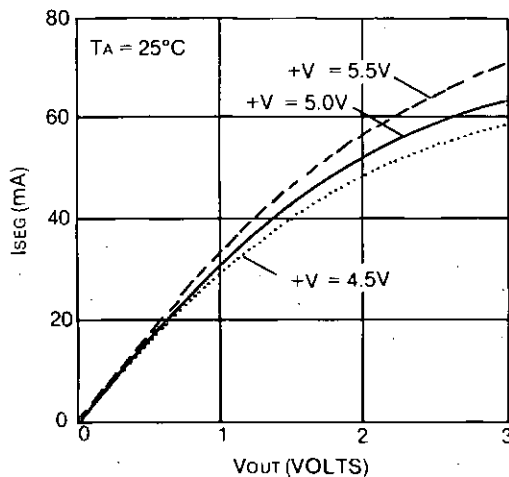

Accuracy

In a Universal Counter crystal drift and quantization errors cause errors. In Frequency, Period and Time Interval modes, a signal derived from the oscillator is used in either the Reference Counter or Main Counter. Therefore, in these modes an error in the oscillator frequency will cause an identical error in the measurement. For instance, an oscillator temperature coefficient of 20ppm/°C will cause a measurement error of 20ppm/°C.

In addition, there is a quantization error inherent in any digital measurement of ± 1 count. Clearly this error is reduced by displaying more digits. In the Frequency mode the maximum accuracy is obtained with high frequency inputs and in Period mode maximum accuracy is obtained with low frequency inputs. As can be seen in figure 9, the least accuracy will be obtained at 10 kHz. In Time Interval measurements there can be an error of 1 count per interval. As a result there is the same inherent accuracy in all ranges as shown in figure 10. In Frequency Ratio measurement can be more accurately obtained by averaging over more cycles of Input B as shown in figure 11.

Figure 9: Maximum accuracy of frequency and period measurements due to limitations of quantization errors

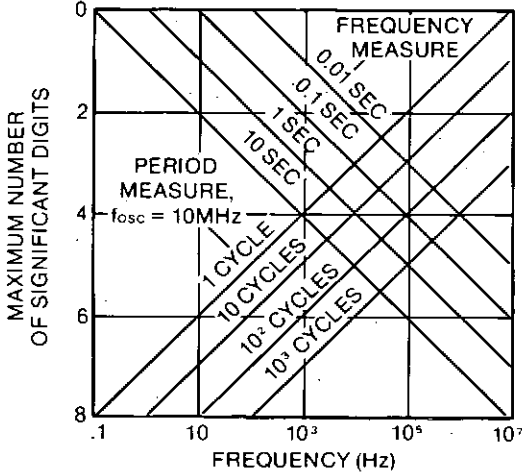

Oscillator considerations

The easiest way of implementing the timebase oscillator is to use a 10MHz crystal (307-799) and associated circuitry as shown in figure 12.

Figure 12: Crystal oscillator circuit

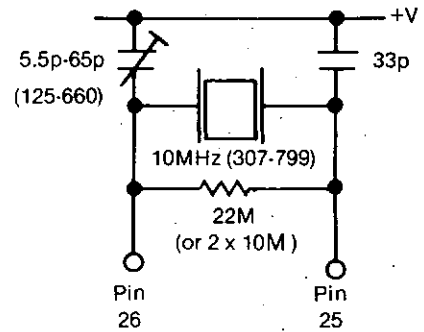
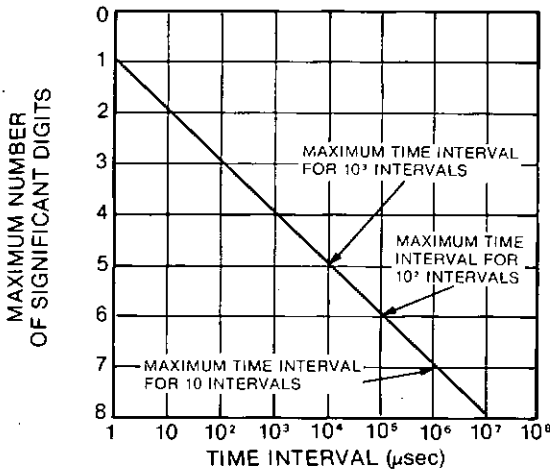

Figure 10: Maximum accuracy of time interval measurement due to limitations of quantization errors



If the 1 MHz enable option is to be used, this may be implemented simply by substituting a 1MHz crystal (307-761) for the 10MHz crystal in figure 12 and connecting the 1MHz enable control circuitry.

An external oscillator, e.g. the RS 10MHz Crystal Oscillator may be used by connecting the oscillator output to pin 24 and connecting the external oscillator, enables control circuitry. (N.B. oscillator output must be input voltage criteria as detailed in maximum ratings and electrical characteristics sections.)

Figure 11: Maximum accuracy for frequency ratio measurement due to limitation of quantization errors

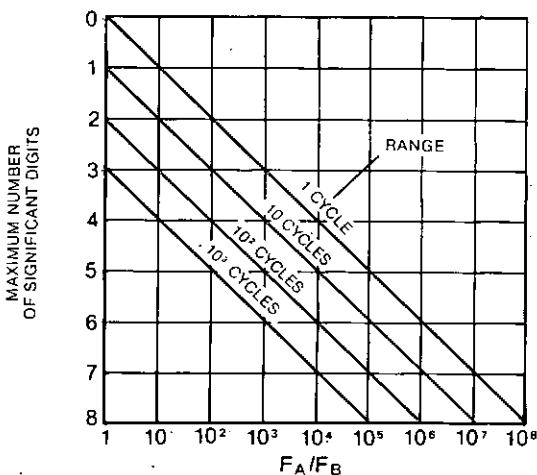

Circuit applications

The RS7216 has been designed for use in a wide range of Universal Counter applications. In many cases, prescalers will be required to reduce the input frequencies to under 10 MHz. Because Input A and Input B are digital inputs, additional circuitry will often be required for input buffering, amplification, hysteresis, and level shifting to obtain a good digital signal. The complexity for doing this can vary widely depending on the sensitivity and maximum frequency required.

Figure 13 Full function RS 7216 circuit

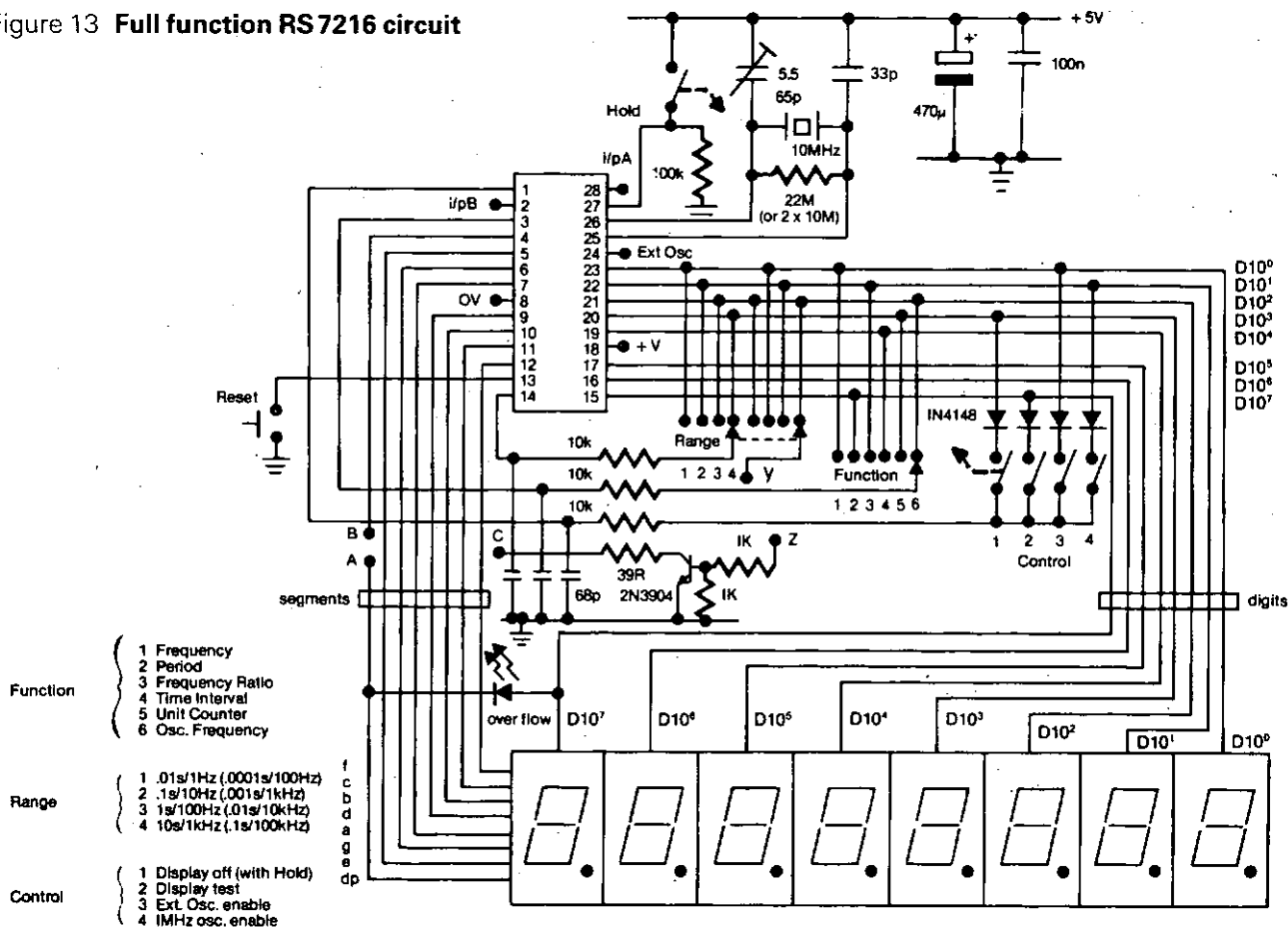

The display may be made up using two multiplexed displays (587-024)

Prescaler techniques

For a full function Universal Counter two of these prescaler circuits will be required. Note that the input to the 74LS90 must be a digital circuit. If decimal point position correction is required see following section.

Note: The output from the 74LS90 comes from the QC rather than QD to obtain an input duty cycle of 40%. If the signals of inputs A or B have very low cycles it may be necessary to use a monostable (74LS123 or similar) to stretch the pulse width to guarantee a 50ns minimum pulse width.

Figure 14: Divide by ten prescaler

Prescaler ÷ 10 up to 50 MHz

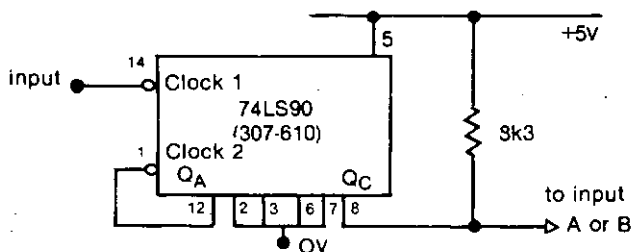

Two circuits required for full functional counter.

Figure 15: Divide by 100 high frequency, single-ended input

Prescaler ÷ 100 up to 150 MHz

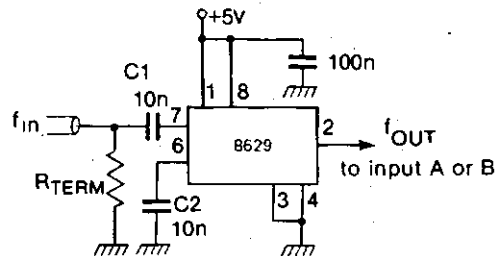

Two circuits required for full functional counter.

Figure 16: Divide by 100 TTL input (DC < f_in < f_max)

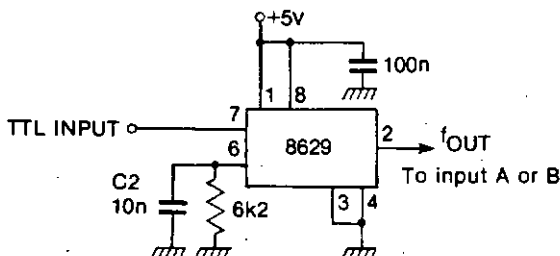

Two circuits required for full functional counter.

For further details of the RS8629, Stock No 307-474, see data sheet 3059.

Decimal point shift facility

When a prescaler is used, or for any other reason, it may be desirable to shift the decimal point. If a ÷10 prescaler is used, the decimal point should be moved one place to the right, and if a ÷100 prescaler is used, it would be moved two places to the right. This is to enable the display to remain reading in kilohertz or microseconds. The circuit below shows a method for achieving this function (N.B. the zero blanking cannot be changed and so one or two zeroes will appear to the left of the decimal point. Also when using the ÷100 prescaler on the 0.01 sec/1 hertz range, it is best to shift the decimal point one place to the left giving measurements in MHz and milliseconds but there may be a blanked digit to the right of the decimal point).

Figure 17: Decimal point shift circuit

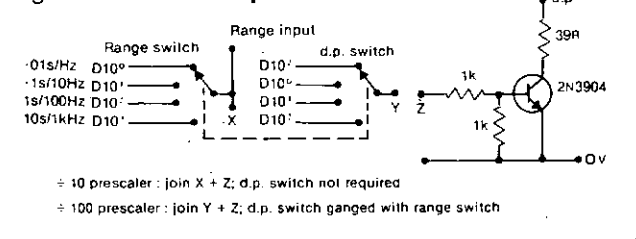

Parts list for full function counter incorporating divide by 100 TTL inputs

Device Type	Stock No.	Qty.
Semi-conductors		
7216A Counter	307-941	1
8629 Prescaler	307-474	2
74LS86 Input gate	307-604	1
4049B Shift register	306-667	1
IN4148 Diode	271-606	4
L.E.D.	587-822	1
7-segment display 0.5"	587-320	8
2N3904 Transistor	294-312	1
Crystal 10MHz	307-799	1
Resistors		
39R metal film	148-152	1
1k metal film	148-506	2
6k2 metal film	148-685	2
10k metal film	148-736	3
100k metal film	148-972	5
22M thick film	158-171	1*
* May be replaced with 2 x 10M 133-330		
Capacitors		
5.5-65p trimmer	125-660	1
33p sub. min. plate ceramic	126-130	1
68p sub. min. plate ceramic	126-152	3
100p sub. min. plate ceramic	126-168	1
1n epoxy cased	125-676	1
10n epoxy cased	125-705	2
100n miniature layer	114-402	5
470µ 10V electrolytic	104-893	1

Time interval mode

The principal of operation of the time interval measurement is that the counter is started by channel A going negative and after the selected number of periods is stopped by channel B going negative. However the first pair of negative edges steers the circuit into this mode of operation and therefore when single shot measurements are to be made it is necessary to "prime" the circuit by a negative going A input followed by a negative going B input (separated by at least 250ns and complying with the specified input characteristics as shown in figure 4).

This priming procedure may be accomplished using the circuit shown in figure 18, but not that it may be necessary to reset the counter before priming. After 'priming', the circuit will count the selected number of periods and display the result as an 'Average'. This priming circuit has no effect on the operation of the universal counter in other modes and may therefore be left permanently connected. (N.B. 'Priming' is not necessary if a repetitive measurement is to be made.)

Figure 18: Priming circuit for single shot operation time interval mode

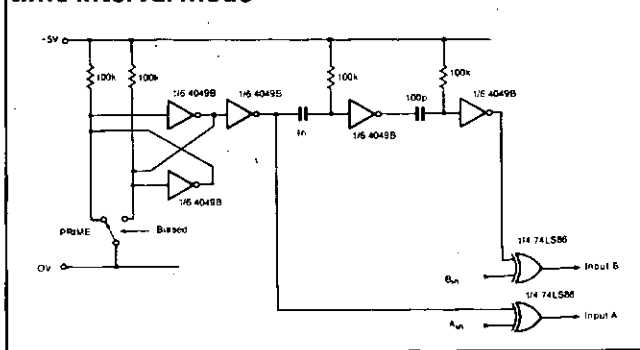

Device Type	Stock No.	Qty.
Miscellaneous		
Priming switch	317-027	1
Reset switch	336-747	1
Hold switch	316-989	1
Range switch – mechanism	327-686	1
– 2 pole, 6 way wafer	327-709	1
– spacer	327-715	1
Function switch – mechanism	327-686	1
– 1 pole, 12 way wafer	327-692	1
– spacer	327-715	1
Control switches	316-973	3
BNC socket-printed circuit	456-093	4
4 way p.c.b. straight plug	467-560	6
5 way p.c.b. straight plug	467-576	1
4 way cable shell	467-611	10
5 way cable shell	467-627	1
4 way angled plug	468-080	1
8 pin D.I.L. socket	402-298	2
14 pin D.I.L. socket	402-305	1
16 pin D.I.L. socket	402-311	1
28 pin D.I.L. socket	402-333	1
Printed circuit board – control	434-484	1
Printed circuit board – display	434-532	1